

Model: **DI045-401V⁺**

Roof Mount Centrifugal Fan

Vertical Discharge

General Information:

Common Applications:

General ventilation, commercial kitchen

Suitable for roof installation up to 15° from horizontal

Galvanised steel base

Powder coated steel cowl, in Color-bond "Dune"

High efficiency backward curved impeller directly driven by IP54 external rotor motor

Easy access to the impeller for wiring, cleaning and maintenance

Removable lifting lugs for ease of installation

Model Specification:

Power / Current	0.73 kW / 3.30 A
Speed	1230 rpm
Power Supply	240V single phase 50 Hz
dBA@3m	52
Mass / Weight	45 kg

+ Refer to wiring diagram WD1-01 available on www.aerovent.com.au/downloads

* Steel construction meets AS1668 for Kitchen Hood Exhaust

* Performance standard ISO 5801

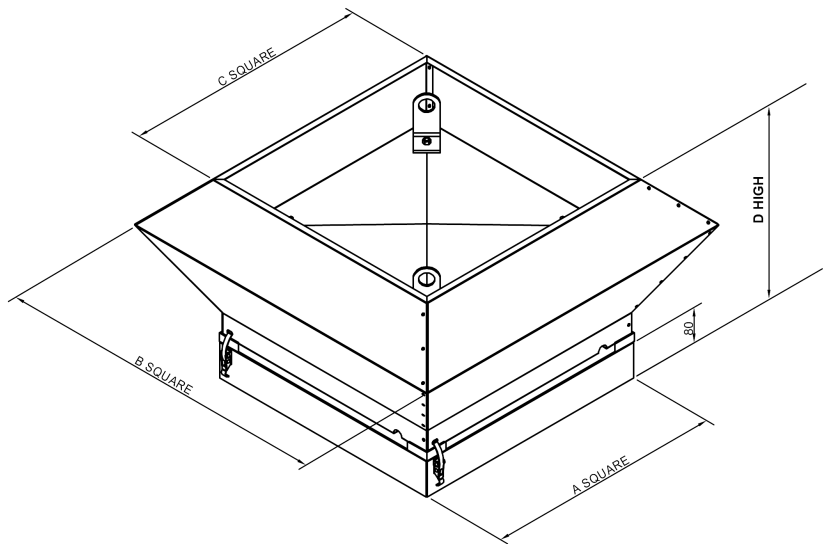
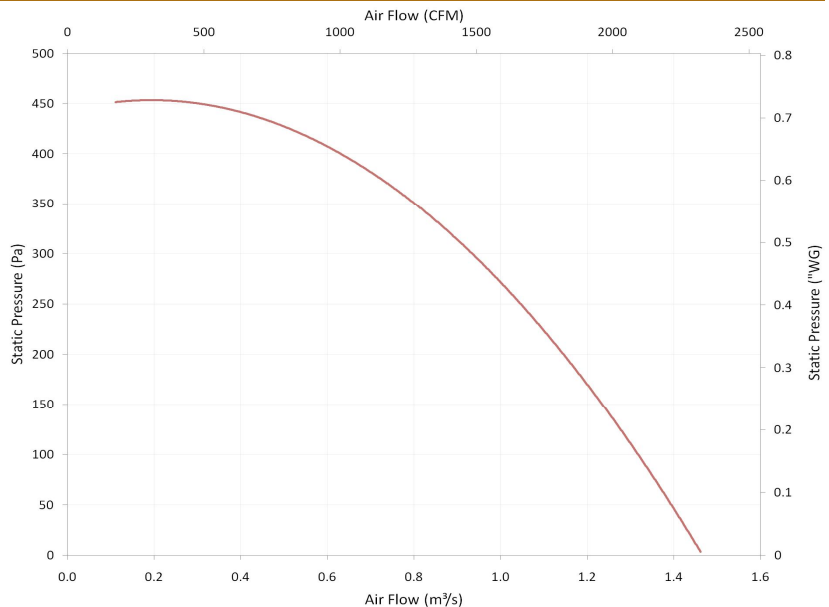

				Recommended upstand dimensions (supplied by others)		
A	B	C	D	Max. outside	Min. inside	Min. height
655	936	689	523	645	545	90

